

■
Pressing up to
Ø 110 mm in just
one action.

REMS Power-Press XL ACC



REMS

for Professionals

Pressing up to \varnothing 110 mm in just one action.
Ultra-fast, e.g. \varnothing 108 mm in only 15 seconds.
With automatic circuit control.
Automatic locking of pressing tongs.

German quality product

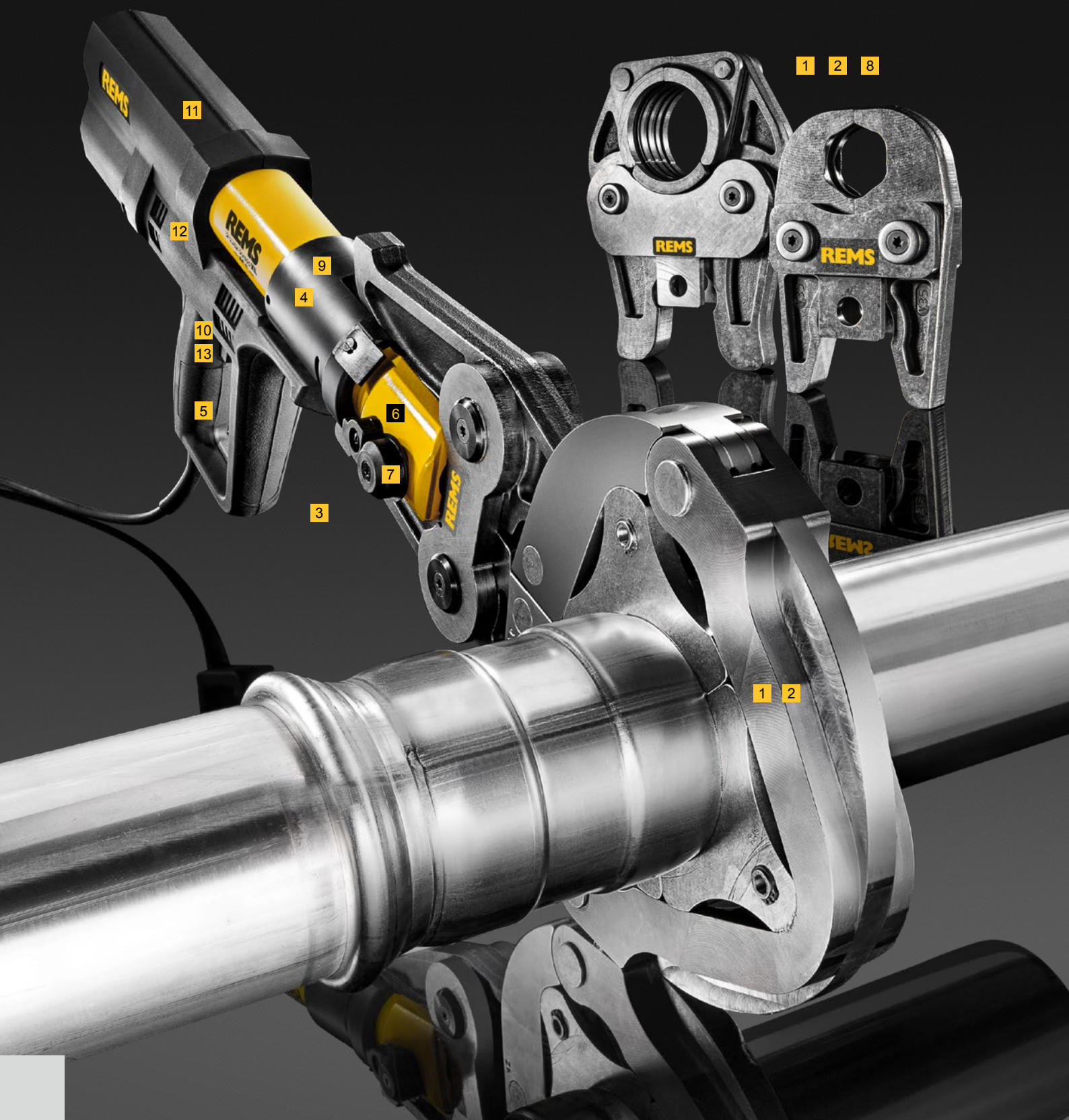

REMS Power-Press XL ACC – universal up to Ø 110 mm.

REMS Power-Press XL ACC sets new standards in economy and user friendliness. It enables pressing up to Ø 110 mm in just one work step. This also applies for Geberit Mapress CARBON STEEL, STAINLESS STEEL and COPPER in drinking water and heating installation up to Ø 108 mm. In addition to the complete range of more than 400 REMS pressing tongs/pressing rings XL, suitable pressing tongs/pressing rings of other makes can also be used with the drive unit. The automatic locking of the pressing tongs and the automatic retraction after completion of the pressing operation (automatic circuit control) give the user additional safety.

- 1 Complete assortment of REMS pressing tongs/pressing rings/pressing rings XL for all common pressfitting systems.
- 2 Highly durable pressing tongs/XL pressing rings made of tenacious, specially hardened special steel. Pressing contours of REMS pressing tongs/pressing rings/pressing rings XL are system-specific and correspond to the respective pressfitting system. Thus perfect systemconformity, safe press jointing.
- 3 Compact, robust, job site-proven. Small in size, slender design, drive unit only 5.5 kg.
- 4 Long working stroke for pressings in a single action, ideal for large dimensions. Ultra-fast, e.g. Geberit Mapress STAINLESS STEEL Ø 108 mm in only 15 seconds.
- 5 Ergonomically designed housing with soft grip and recessed handle.
- 6 Swivelling pressing tongs/adaptor tongs seat.
- 7 Secure seating of pressing tongs by automatic locking.
- 8 Also suitable for other suitable makes of pressing tongs/pressing rings.
- 9 Adjustable hand guard.
- 10 **Pressing operation by touch-control with ACC**
For reliable service, operating and functional safety. Automatic retraction after completion of pressing operation (automatic circuit control).
- 11 Enormous thrust and pressing force for fast and perfect press jointing. Thrust force 32 kN.
- 12 Powerful electro-hydraulic drive with proven universal motor 450 W, robust planetary gear, eccentric reciprocating pump and compact high power hydraulic system.
- 13 Safety tip switch.

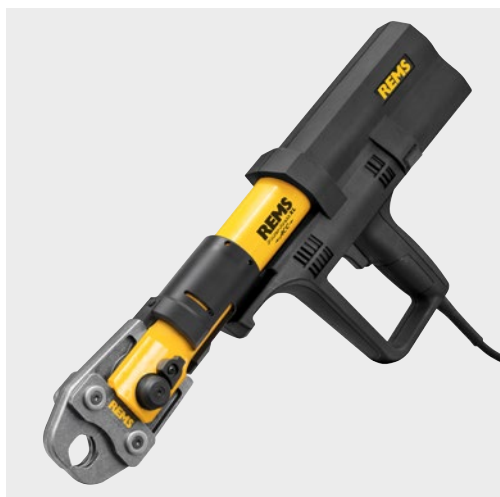



REMS Power-Press XL ACC

REMS Power-Press XL ACC Basic-Pack

Electro-hydraulic radial press with automatic circuit control for making press joints Ø 10–108 (110) mm, Ø 3/8–4". For driving REMS pressing tongs/pressing rings/XL pressing rings and other suitable makes of pressing tongs/pressing rings. Rotating pressing tongs seat with automatic locking. Electro-hydraulic drive with proven 230 V, 50–60 Hz, 450 W universal motor, robust planetary gear, eccentric reciprocating pump and compact high power hydraulic system, safety inching switch. In transport case.

Art.-No. 579010 R220

Accessories



REMS Power-Press XL ACC drive Unit

Art.-No. 579000 R220

REMS XL pressing rings (PR-3S)

Heavy duty XL pressing rings XL (PR-3S) and Z6 XL adapter tongs made of forged and specially hardened special steel. The pressing contours of the REMS XL pressing rings (PR-3S) are system-specific and correspond to the pressing contours of the respective press fitting systems. Perfect system-conformant, reliable pressing as a result.

M 66,7 XL (PR-3S)*

Art.-No. 579107 R

M 76,1 XL (PR-3S)*

Art.-No. 579101 R

M 88,9 XL (PR-3S)*

Art.-No. 579102 R

M 108,0 XL (PR-3S)*

Art.-No. 579103 R

Z6 XL adapter tongs

For driving the REMS pressing rings M 64.0–108.0 XL (PR-3S) with REMS Power-Press XL

Art.-No. 579120 R

*The Z6 XL pressing tongs are required for driving the XL pressing rings (PR-3S).



REMS pressing tongs/pressing rings/pressing rings XL

for all common pressfitting systems.

REMS cropping tongs for threaded rods.



REMS cable shear for electric cable

Art.-No. 571887

Transport case with inlays and practical carrying handles

Art.-No. 579240 R

Sale through specialist dealers.



REMS (UK) Ltd.

Unit 5 · Ash Industrial Estate
Flex Meadow · Harlow · Essex CM19 5TJ
Phone +44 12 79 41 36 98
Fax +44 12 79 41 37 04
www.rems.de · GBR@rem.de



www.rems.de



www.youtube.com/remstools



www.facebook.com/remstools



www.twitter.com/remstools